

The most accepted and respected engine-driven cooler in the gas compression industry.

# Model EH

## Model EH Specifications

- Fan diameters from 24" to 168".
- Engine drive and electric motor drive configurations.
- Typical compression HP: 100-2,000.

## Model EH Advantages

- This compact, unitized cooler combines engine and compressor cooling in a single unit.
- The unique sloped section arrangement provides greater cooling capacity within a given plot area and reduces packaging costs by minimizing the cooler footprint.
- Forced-draft design moves cool air through the unit – resulting in lower fan horsepower requirements and higher efficiency.
- Plenum design, adjustable shutters and/or fixed turning vanes are integral to the design and help guide airflow through the cooler, improving exit air velocity and reducing air recirculation.
- Vertical discharge minimizes the effects of wind variation and location of adjacent equipment.
- Rotating components are located in the cool air stream of the cooler promoting longer life, ease of visual inspection and safer maintenance.
- Optional Model EH Integrated Shipping design to reduce shipping height and transport costs.



144-EH



Optional EH Integrated Shipping design allows "face-down" transport



Optional bug screen / lint screen



Optional warm air recirculation system

**HARSCO**  
INDUSTRIAL

Air-X-Changers  
Hammco

5615 South 129th East Avenue | Tulsa, OK 74134 USA  
918-619-8000 USA | FAX 918-384-5000 USA | harscoaxc.com

Insight onsite.™

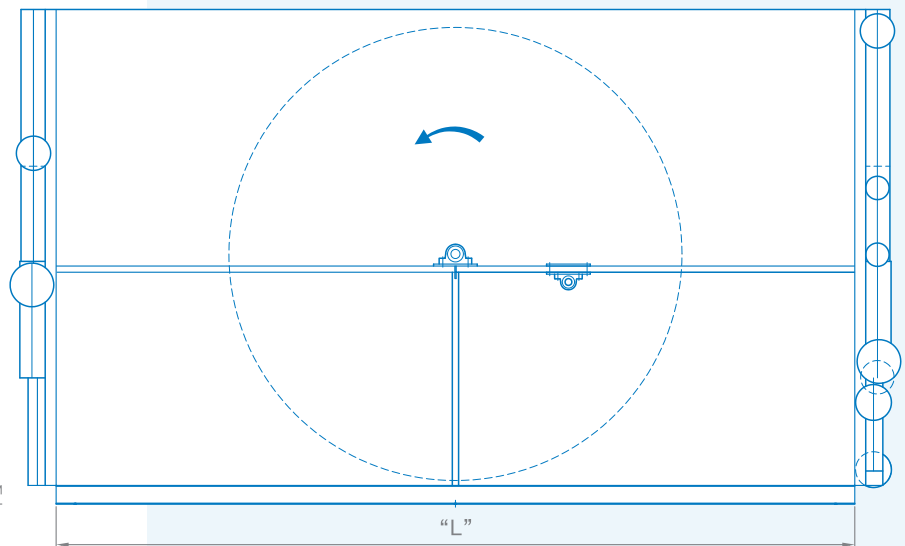
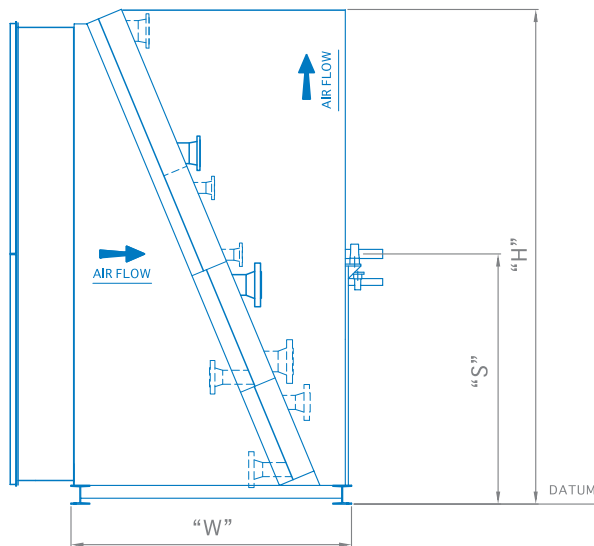

## Optional Features

- Cooler finish per customer specifications, including tint-to-match paint and galvanizing.
- Auxiliary louvers (manual or automated) upstream of the cooling sections for additional cold-weather protection.
- Automated louver control, typically using pneumatic actuators.
- Warm air recirculation systems to better control process outlet temperature in cold-weather climates.
- Hailguard over air discharge duct to protect cooling sections.
  - *Light Duty*
  - *Heavy Duty / Walk-On*
  - *No Profile / Flush Mounted: protection that doesn't add to the height of the cooler.*
- Low noise emission fans.
- Bug screens / lint screens over air intake to prevent fouling.
- Internal or external maintenance walkway or platform.
- Model EH Integrated Shipping design to reduce shipping height and transport costs.
- Integrated tool box and battery / maintenance storage.

Model EH				
Fan Diameter	L	W	H	S
24	28	33	32	16
32	40	36	41	20
36	52	39	46	23
42	52	44	59	32
48	64	47	66	36
54	64	54	84	44
60	64-88	52-64	80-103	37-55
72	88	58-64	93-104	46-55
81	88-100	64-69	104-115	55
84	100-112	69	115	55
93	124-136	69	115	55
96	136-160	69-76	115-133	55-66
108	160-184	73-84	122-147	62
120	184-208	80-88	136-158	69
132	208-232	84-93	147-169	74
144	232-280	90-96	158-178	80
156	256-304	94-100	172-186	87
168	256-328	108-113	186-197	93

L = Base beam length. W = Base beam width. H = Height. S = Grade to c/l shaft. Dimensions shown in inches. For estimation only; dimensions may vary.



Air-X-Changers  
Hammco